



**SERFILCO**<sup>®</sup>  
INTERNATIONAL

## C.P.S. Water flush pumping station

BULLETIN  
P-???  
May 2014



### HIGH EFFICIENCY AND LOW ENERGY USAGE FOR:

#### Protection of double Mechanically sealed pumps

- Flows up to 1.4 LPM and up to 5 bar pressure.
- Magnetically coupled gear pump, for leak free operation.
- Simple operation, one valve to adjust.
- 110 litre holding tank.
- Simple push fit connections.
- Ball cock for automatic level control.
- Optional Dri-Stop protection.

The C.P.S. series collection and pumping station is for use with Serfilco's range of double mechanically sealed pumps. A constant supply of pressurised water is needed to cool the seal faces & to protect both the front and rear seal during normal operating conditions and in the event of the main pump running dry. An optional Dri-Stop can be fitted to further protect the pump in the event of a system failure.

The C.P.S. is fitted with a large 110 litre holding tank & an integral ball cock for automatic level control. The magnetically coupled gear pump fitted to the C.P.S. provides the low flow and high pressure needed to prevent process solution leaking into the water flushing system.

The C.P.S. can be manufactured to suit individual customer's requirements, with 240v or 110v pumps with the optional Dri-Stop available in 24v or 115v.

The C.P.S. is quick and simple to install with push fit connections and a simple ball valve to adjust the system to the correct pressure to suit the mechanically sealed pump.

A maintenance free design allows the C.P.S. to be set once, with no need for re-adjusting every time the system is re-started.

Simply set the pressure gauge on the C.P.S to 0.7 bar above the pressure generated by the mechanically sealed pump.



C.P.S. models are designed for use with water only, incorrect setting of the C.P.S. can result in process solution passing the mechanical seals & entering the C.P.S.

See the drawing below for dimensions. Please note that all dimensions shown are a guide only.

A Dri-Stop is not shown on the drawing; however the overall dimensions are the same for a C.P.S fitted with a Dri-Stop.

C.P.S. is available in single phase only, with a choice of 240v or 110v pump. The motor fitted to the C.P.S. is rated to IP55 and painted in a 2 part epoxy finish.

The optional Dri-Stop is available in 24v or 115v. This will require wiring into the main pumps control panel, a wiring guide will be supplied with each Dri-Stop.

C.P.S. is supplied with 60ft of 3/8" polyethylene tubing, 10ft of 1/4" tubing and 2 off 1/4"-3/8" push fit reducers.

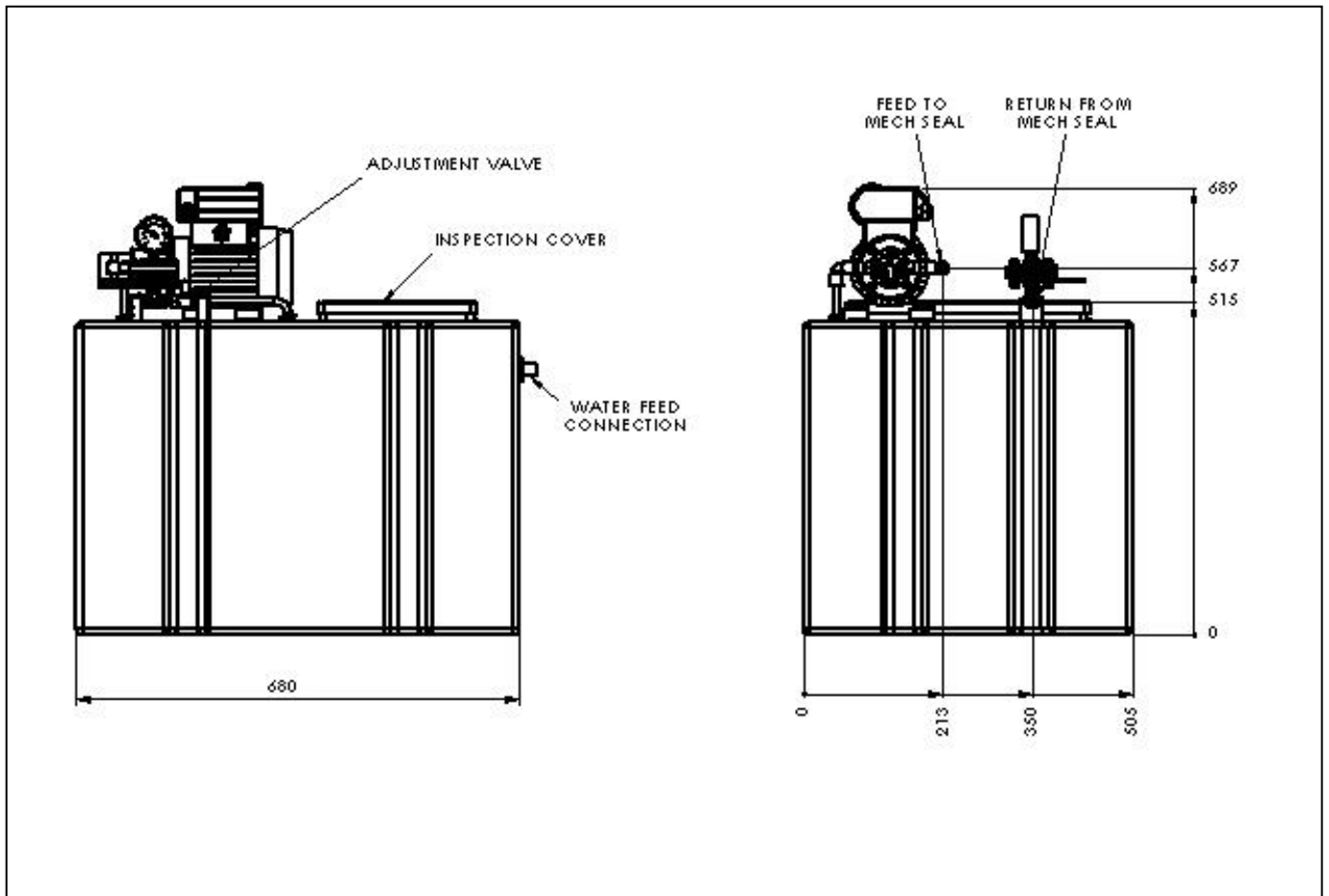

**TO ORDER, use Price Code Number**

**TABLE I**

Select the correct voltage, and Dri-Stop options if required.

| Description   | Voltage                  | Price Code          |
|---|--------------------------|---------------------|
| Collection & Pumping Station                              | 240v/50Hz/1phase         | 01-5010-1           |
| Collection & Pumping Station                              | 110v/50Hz/1phase         | 01-5010-1-110       |
| Collection & Pumping Station<br>fitted with 24v Dri-Stop  | 240v/50Hz/1phase<br>24v  | 01-5010-1-DS24      |
| Collection & Pumping Station<br>fitted with 115v Dri-Stop | 240v/50Hz/1phase<br>115v | 01-5010-1-DS115     |
| Collection & Pumping Station<br>fitted with 24v Dri-Stop  | 110v/50Hz/1phase<br>24v  | 01-5010-1-110-DS24  |
| Collection & Pumping Station<br>fitted with 115v Dri-Stop | 110v/50Hz/1phase<br>115v | 01-5010-1-110-DS115 |

**Additional equipment - C.P.S.**

| Description          | Price Code |
|----------------------|------------|
| 3/8" tubing, per ft. | 01-5012-PE |
| 1/4" tubing, per ft. | 01-9003    |
| 24v Dri-Stop         | 99-1116-RE |
| 115v Dri-Stop        | 99-1152-RE |



**SERFILCO® INTERNATIONAL**

Siemens Road, Northbank Industrial Estate  
Irlam, Manchester  
M44 5AH UK  
Email : sales@serfilco-international.com

Tel: +44 161 775 1910  
Fax: +44 161 775 3696  
Web: www.serfilco.com