

SERFILCO®

SERIES 'DSS' MAGNETIC-COUPLED PUMPS

BULLETIN
P-507-1
JAN. 1996

RELIABLE, TROUBLE-FREE PUMPING
Seal-less and "Leak-proof" for total Solution Containment

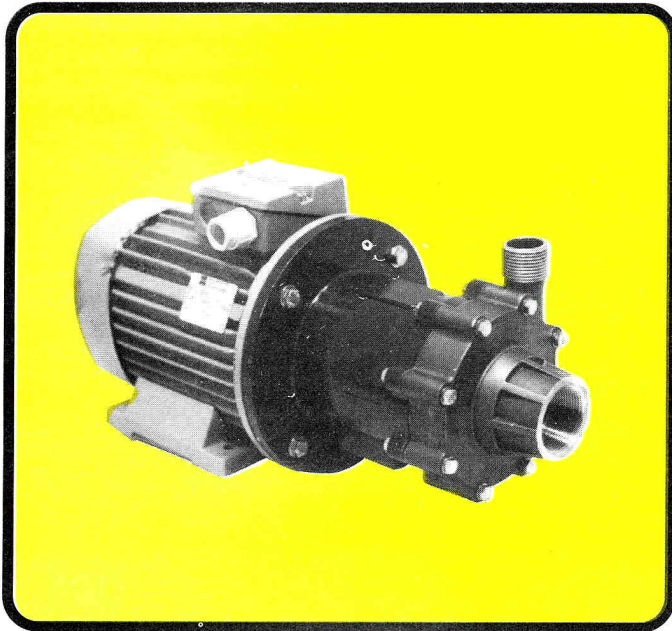

- **Corrosion resistant**
316 Stainless Steel
Refer to Chemical Resistance Chart
- **Centrifugal** - Quiet, vibration-free
- **Flows to 360 LPM or 19m TDH @ 50 Hz**
(2850 RPM)
- **Maximum liquid temperature**
120° C - continuous
- **Rugged construction**
Designed for continuous duty
Horizontal or vertical discharge
- **Continuous duty motor**
All carry 1.15 service factor at 50 Hz

SERIES 'DSS' Magnetic Coupled Pumps are seal-less, providing for maintenance-free and "leak-proof" operation. The magnetic coupling acts as a clutch to provide overload protection. The broad range of construction materials allows for a variety of applications and service with most corrosive solutions.

The impeller magnet assembly floats in the radial magnetic field set up by the motor driven external drive magnet. The impeller is designed to deliver the maximum flow and pressure utilizing the available strength of the synchronized magnets.

The standard diameter impeller is suitable for water-like liquids to 1.2 specific gravity. Liquids having a higher specific gravity can be pumped if the outlet flow is restricted.

TYPICAL APPLICATIONS: *Filtering, Circulation, Processing and Transfer*

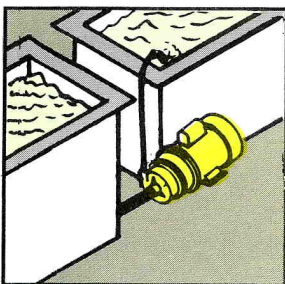

WASTE TREATMENT

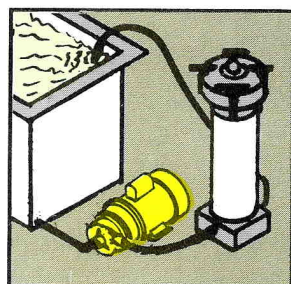

FILTER SYSTEM

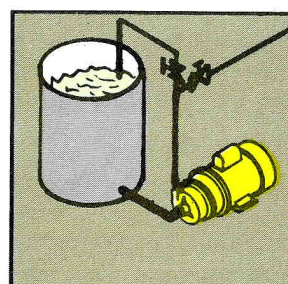

**MIXING and TRANSFER
PUMPING**

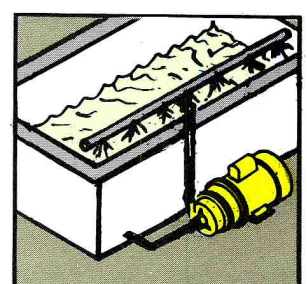

RECIRCULATION

SPECIFICATIONS

Materials in contact with pumped liquid:
 316SS/EPDM or Viton/Carbon - PTFE or graphite
 Maximum temperature: 120° C
 Suction / discharge ports: BSP (F) / BSP (M)
 Motors: IPSS - Cast iron frame - 2850 RPM
 1 phase and 3 phase; motors with special voltages / Ex rating available optionally

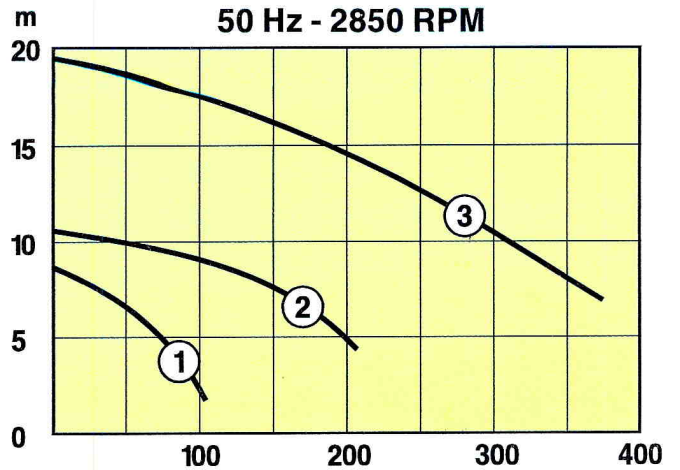

TO ORDER

FLOW CURVE	MODEL NUMBER	MOTOR (2850RPM)		CODE NUMBER
		HP (kw)	VOLTAGE	
1	DSS1x¾-MSSK-CM.5	.5 (.37)	220-240/1/50	01-4420-01
	DSS1x¾-MSSK-DM.5		220-380-415/3/50	01-4420-03
2	DSS1½x1-MSSK-CM1	1 (.75)	220-240/1/50	01-4421-01
	DSS1½x1-MSSK-DM1		220-380-415/3/50	01-4421-03
3	DSS1½x1¼-MSSK-DM2	2 (1.5)	220-380-415/3/50	01-4422-03

DIMENSIONS

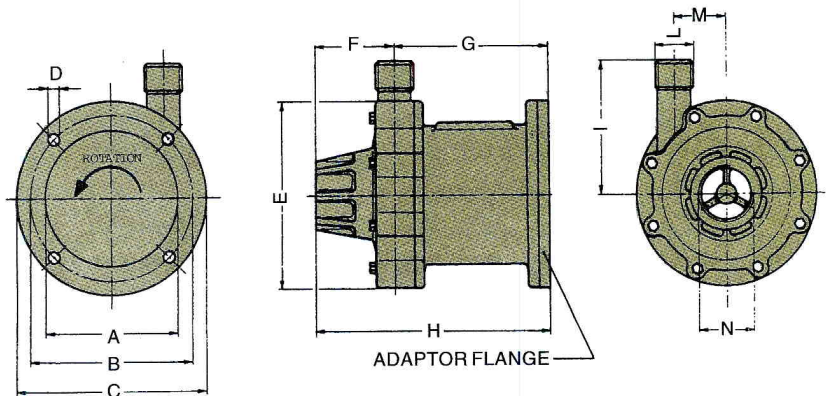

PUMP MODEL	MOTOR (B3/B5)	DIMENSIONS - mm											
		A	B	C	D	E	F	G	H	I	L	M	N
DSS 1 x ¾	71FR	110	130	160	7	140	57	137	194	89	¾ BSP (M)	46	1 BSP (F)
DSS 1½ x 1	80FR	130	165	200	11	151	69	143	212	98	1 BSP (M)	44	1½ BSP (F)
DSS 1½ x 1¼	90FR	130	165	200	11	199	82	176	258	124	1¼ BSP (M)	62	1½ BSP (F)

PARTS

ITEM	DESCRIPTION
1	Bolt/washer/nut
2	Pump casing
3	"O"-ring
4	Thrust bearing & screws
5	Spindle/rear thrust ring
7	Impeller
8	Impeller magnet
9	Bushing
10	Liner
11	Drive magnet
12	Bolt/nut
13	Bracket

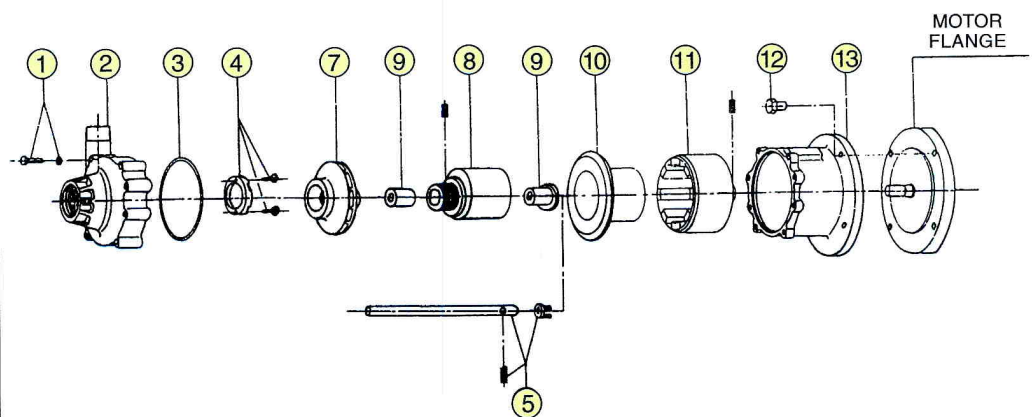

SERFILCO® EUROPE

Broadoak Industrial Park Phone: 0161-872-1317
 Ashburton Road West, Trafford Park FAX: 0161-873-8027
 Manchester M17 1RW England

DISTRIBUTED BY