



Satin-Saver – Continuous Long life Filtration & Purification for Satin-Ni Process



SERFILCO Satin-Saver Filtration systems are a user friendly system designed for the long-life, continuous operation of Satin Nickel plating baths.

Using proportionally controlled dosing alongside Plate & Paper filtration and Active Carbon purification the range of final finish can be adjusted whilst the bath life can be extended beyond normal operating parameters, saving users downtime, lowering maintenance costs and reducing rejects.



Typical Layout

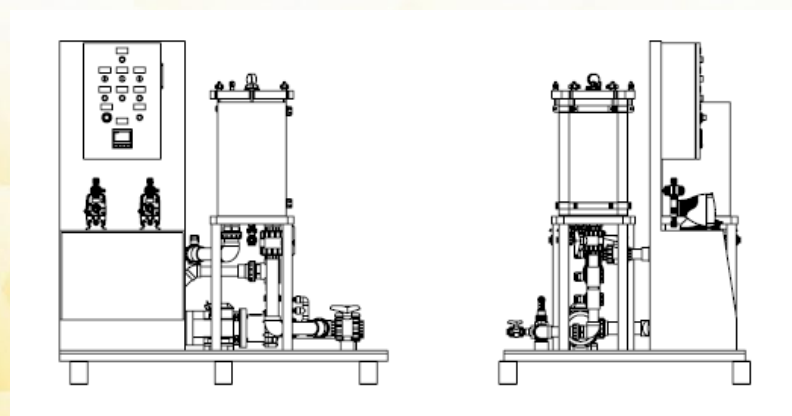
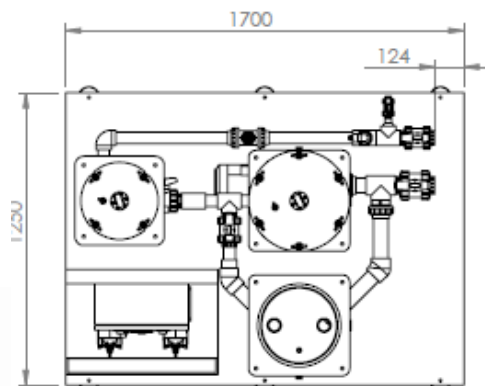
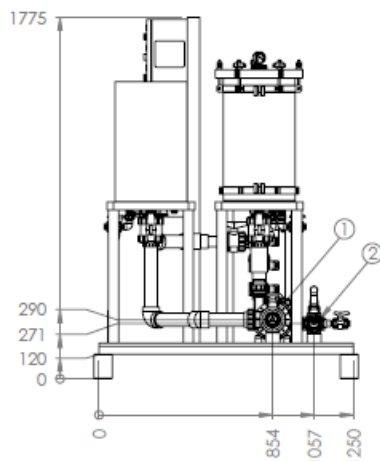
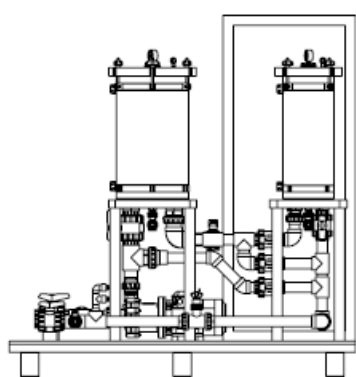

Includes

- Control Panel & Inverter
- Plate & Paper Filter
- Slurry Tank
- Cartridge Trap Filter
- Flow meter
- Mag-Drive Circulation Pump
- 2 x auto-dosing pumps

Model	Flow	Filter	Media	Plates	Surface Area	Pump	Motor	Dosing
PPSS1	1000-3000lph	FM Disk	290 x 50mm	60	3m ²	SG15	3.0kW	2 x Digi-Pulse 4-20A
PPSS2	3000-6000lph	Megaflor Disk	355 x 75mm	65	6.5m ²	SG15	3.0kW	2 x Digi-Pulse 4-20A

SERFILCO International Ltd

+44 (0)161 775 1910

global@serfilco.com

www.serfilco.co.uk

GLOBAL PRODUCTS, LOCAL SERVICE & ADVICE YOU CAN RELY ON